

Instruction Manual

Operation • Safety • Maintenance



Meets applicable requirements of
ASME/ANSI B30.1 2004
AU/NZS 2693:2007

Read this instruction manual before using the
First Responder Jack.

Important! First Responder Jacks are designed to be operated by properly trained and clothed rescue personnel in emergency or emergency training applications only.



Contents

First Responder Jack Components	1
Safety	3
Safety Symbols	3
Safety Warnings.	4
Handle Safety Decal	5
General Safety.	6
Operation Instructions	7
Attaching and Using the First Responder Base	7
Raising a Stationary Load.	9
Lowering a Stationary Load	11
Clamping or Winching	12
Maintenance Instructions	14
Cleaning	14
Binding	14
Storing the Jack.	14
Inspection	14
Lubrication	15
Repair.	15
Parts	16
Specifications	18
Limited Warranty	19



Hi-Lift Jack Company

P.O. Box 228
Bloomfield, IN 47424-0228 USA

Toll Free: 800.233.2051

Direct: 812.384.4441

Fax: 812.384.4592

Web: <http://firstresponder.hi-lift.com>

To the Owner / User

Thank you for purchasing the First Responder Hi-Lift® Jack. With proper use and care, your jack will give you years of dependable service. You can use the First Responder Hi-Lift® Jack in many ways, including:

- Lifting stable loads.
- Winching loads.
- Clamping.
- Spreading.
- Raising vehicles or other loads (when properly chocked, blocked, wedged and stabilized).

Store these instructions in the handle of your jack. Use only genuine Hi-Lift® replacement parts. Using replacement parts not supplied by Hi-Lift® Jack Company will make the jack unsafe for use and void the warranty.

First Responder Jack Components

Get to know the components of your jack before you begin use.

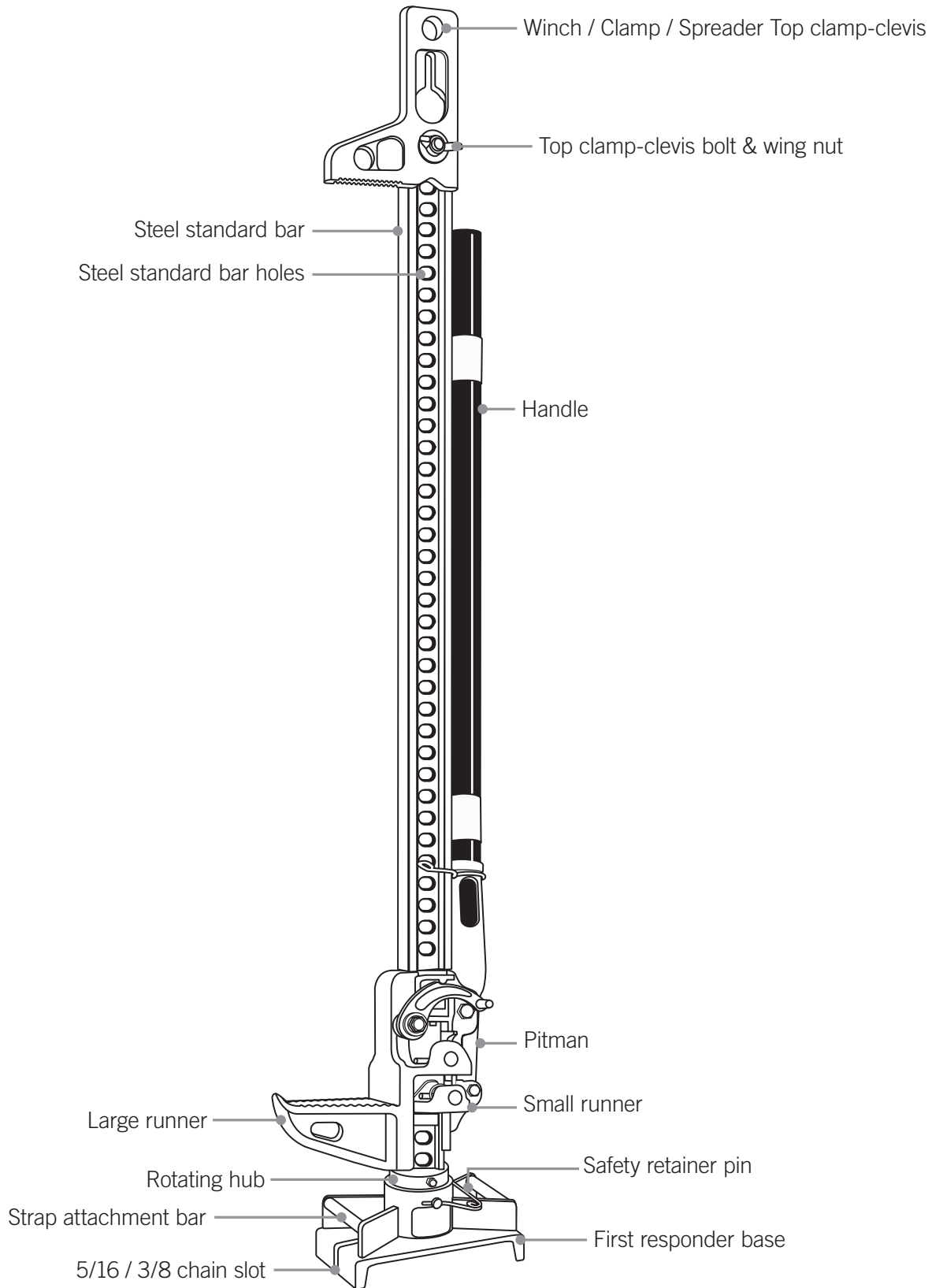

Components · Running Gear

The following shows the parts associated with the running gear:

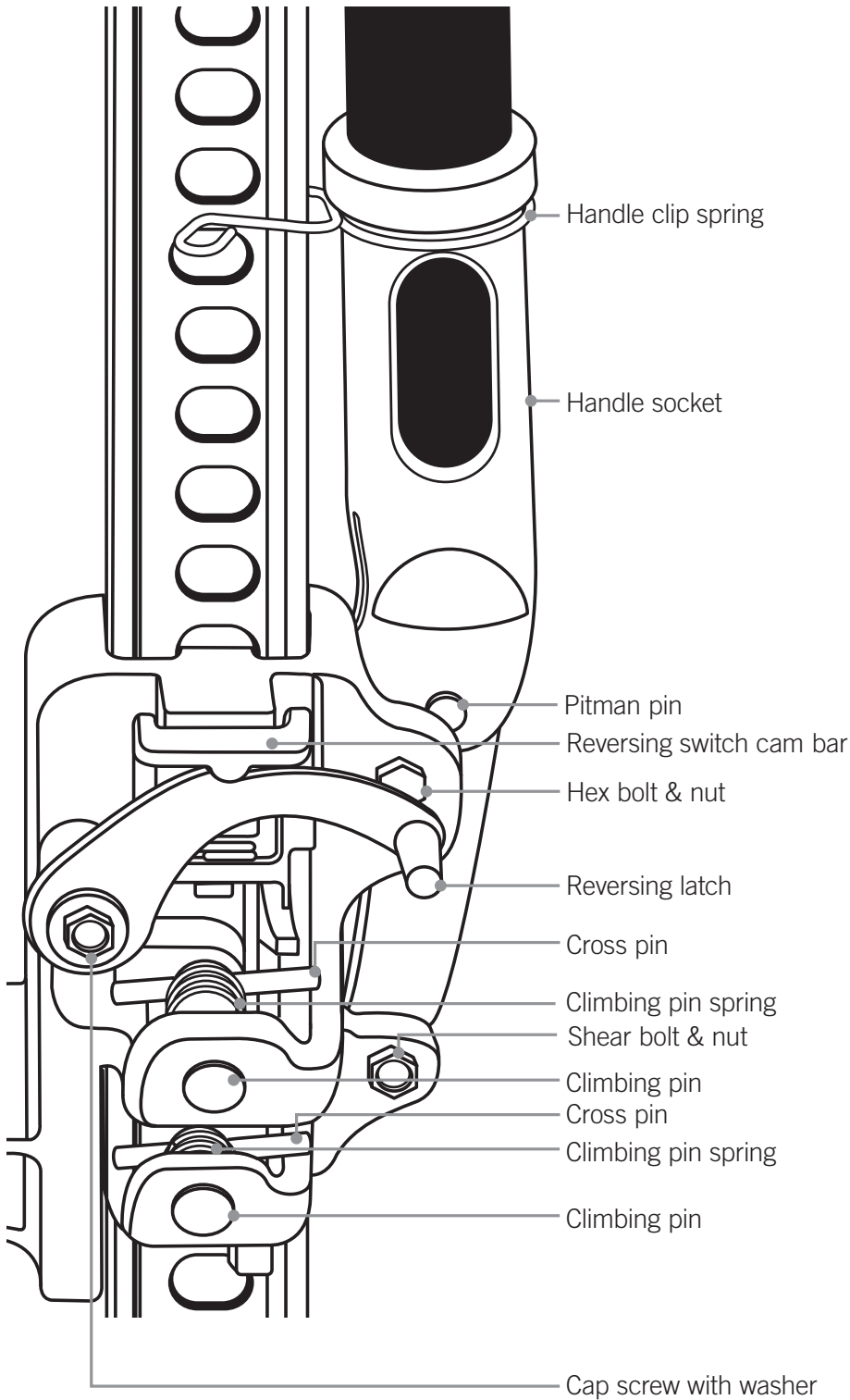

Safety



All users must read and understand the instructions and safety warnings in this manual and the safety labels placed on the product before using the jack. Each user must use the jack safely and maintain it properly.

If any users are not fluent in English, have someone read the instructions to them. Manuals are also available in other languages upon request at no charge.

If you have any questions about using the jack safely or if you need a new label or manual, see the contact information on the opposite page.

Important! First Responder Jacks are designed to be operated by properly trained and clothed rescue personnel in emergency or emergency training applications only.

Safety Symbols

 **DANGER**

The DANGER! safety symbol indicates a hazard or unsafe practice that **will** result in serious injury or death.

 **WARNING**

The WARNING! safety symbol indicates a hazard or unsafe practice that **could** result in serious injury or death.

Safety Warnings

⚠ DANGER



DO NOT USE THE JACK TO SUPPORT OR STABILIZE A LOAD. Using the jack to support or stabilize a load may result in unexpected movement and result in serious injury, being crushed and death. Always securely chock, wedge, and block (stabilize) the load to be lifted. Never place any part of the body under a raised load without properly chocking and supporting the load (6 points minimum).

Using the jack on curved or tubular vehicle bumpers will result in the vehicle slipping off the jack and falling, causing serious injury or death. Use the Bumper Lift or Lift-Mate to lift most vehicles with curved bumpers or plastic bumpers.



When using the jack as a winch:

Always use chains or tow straps that have a greater working load than the jack. If a chain or tow strap breaks while winching, the load could shift or the chain or tow strap could snap back.

When used as a winch, the top clamp-clevis will support up to 5,000 lbs. (2273 kg). Going over this limit will result in the top clamp-clevis bending or breaking, causing the load to move or the chain or tow strap to snap back. This will result in serious injury or death.

When using the jack for clamping, the maximum clamping force of the top clamp-clevis is 5,000 lbs. (2,273 kg). If you exceed this limit, the top clamp-clevis could bend or break, resulting in serious injury or death.



Unexpected movement of the jack handle may result in the user being struck causing serious injury or death. Always keep your head away from and out of the jack handle path of movement.

The jack handle may move rapidly when moving the reversing latch and cause serious injury or death. **Always place the handle against the steel standard bar with the handle clip spring holding it up before moving the reversing latch.** This will prevent the handle from moving up and down rapidly. Securely hold on to the jack handle so your hands do not slip and ensure the handle is not in the horizontal position when moving the reversing latch.

Important! During lifting and lowering, the weight of the load pushes **up** against the jack's handle. If your hands slip off the handle, or if the handle is horizontal when you move the reversing latch, it may move up very quickly.



Attempting to lift more than one wheel at a time may result in tip over, unexpected movement and serious injury or death. Always securely chock, wedge and block the load (six points minimum) to avoid tip over.

⚠ WARNING





The jack, while standing vertical and unsupported, may tip over and cause serious injury or death. Always support the jack or lay it on its side when not in use.

This jack will not operate safely without proper lubrication. Using the jack without proper lubrication will result in poor performance and damage to the jack. The jack is not self-lubricating, inspect the jack before use and lubricate when necessary.

Handle Safety Decal

Important! Replace handle safety decal if damaged or removed.

⚠ DANGER

The following hazards or unsafe practices will cause serious injury or death

DO NOT USE THE JACK TO SUPPORT OR STABILIZE A LOAD. Using the jack to support or stabilize a load may result in unexpected movement and result in serious injury, being crushed and death. Always securely chock, wedge, and block (stabilize) the load to be lifted. Never place any part of the body under a raised load without properly chocking and supporting the load.

Using the jack on curved or tubular vehicle bumpers will result in the vehicle slipping off the jack and falling, causing serious injury or death. Use the Bumper Lift or Lift-Mate to lift most vehicles with curved bumpers or plastic bumpers.

When using the jack as a winch:

Always use chains or tow straps that have a greater working load than the jack. If a chain or tow strap breaks while winching, the load could shift or the chain or tow strap could snap back.

When used as a winch, the top clamp-clevis will support up to 5,000 lbs. (2273 kg). Going over this limit will result in the top clamp-clevis bending or breaking, causing the load to move or the chain or tow strap to snap back. This will result in serious injury or death.

When using the jack for clamping, the maximum clamping force of the top clamp-clevis is 5,000 lbs. (2273 kg). If you exceed this limit, the standard top clamp-clevis could bend or break, resulting in serious injury or death.

Unexpected movement of the jack handle may result in the user being struck causing serious injury or death. Always keep your head away from and out of the jack handle path of movement.

The jack handle may move rapidly when moving the reversing latch and cause serious injury or death. Always place the handle against the steel standard bar with the handle clip spring holding it up before moving the reversing latch. This will prevent the handle from moving up and down rapidly. Securely hold on to the jack handle so your hands do not slip and ensure the handle is not in the horizontal position when moving the reversing latch.

Important! During lifting and lowering, the weight of the load pushes up against the jack's handle. If your hands slip off the handle, or if the handle is horizontal when you move the reversing latch, it may move up very quickly.

Attempting to lift more than one wheel at a time may result in tip over, unexpected movement, and serious injury or death. Always securely chock, wedge, and block (6 points minimum) to avoid tip over.

Handle force required to raise 4,660 lbs. is 177 lbs. at 34" on the handle. Maximum rated load is 4,660 lbs. (2273 kg) up to 48" (121 cm), tested to 7,000 lbs. (3175 kg). Upper 12" of 60" jack is rated to 2,660 lbs. (1209 kg) only, tested to 4,000 lbs. (1818 kg). If you overload the jack during operation, the shear bolt will break. If the shear bolt breaks, as it will at 7,000 lbs. (3175 kg), the load should be supported, but the jack's handle will drop freely. Use a jack with a larger load capacity to lower the load safely to the ground. Do not replace the shear bolt with a bolt of greater strength as this could cause the jack to fail and drop the load. Always use a shear bolt supplied by Hi-Lift Jack Company. Do not replace the shear bolt while the jack is under load.

⚠ WARNING

The following hazards or unsafe practices may cause serious injury or death

The jack, while standing vertical and unsupported, may tip over and cause serious injury or death. Always support the jack or lay it on its side when not in use.

This jack will not operate safely without proper lubrication. Using the jack without proper lubrication will result in poor performance and damage to the jack. The jack is not self-lubricating, inspect the jack before use and lubricate when necessary.



Important! First Responder Jacks are designed to be operated by properly trained and clothed rescue personnel in emergency or emergency training applications only.

All users must read and understand the instructions and safety warnings in the instruction manual and on this product before using the jack. Each user must use the jack safely and maintain it properly.



If any users are not fluent in English, have someone read the instructions to them. Manuals are also available in other languages upon request at no charge.

If you have any questions about using the jack safely, need a new label or manual contact:

Hi-Lift Jack Company
P.O. Box 228
Bloomfield, IN 47424-0228 USA

Toll Free: 800.233.2051
Direct: 812.384.4441
Fax: 812.384.4592
Web: <http://firstresponder.hi-lift.com>

⚠ DANGER

The following hazards or unsafe practices will cause serious injury or death

DO NOT USE THE JACK TO SUPPORT OR STABILIZE A LOAD. Using the jack to support or stabilize a load may result in unexpected movement and result in serious injury, being crushed and death. Always securely chock, wedge, and block (stabilize) the load to be lifted. Never place any part of the body under a raised load without properly chocking and supporting the load.

Using the jack on curved or tubular vehicle bumpers will result in the vehicle slipping off the jack and falling, causing serious injury or death. Use the Bumper Lift or Lift-Mate to lift most vehicles with curved bumpers or plastic bumpers.

When using the jack as a winch:

Always use chains or tow straps that have a greater working load than the jack. If a chain or tow strap breaks while winching, the load could shift or the chain or tow strap could snap back.

When used as a winch, the top clamp-clevis will support up to 5,000 lbs. (2273 kg). Going over this limit will result in the top clamp-clevis bending or breaking, causing the load to move or the chain or tow strap to snap back. This will result in serious injury or death.

When using the jack for clamping, the maximum clamping force of the top clamp-clevis is 5,000 lbs. (2273 kg). If you exceed this limit, the standard top clamp-clevis could bend or break, resulting in serious injury or death.

Unexpected movement of the jack handle may result in the user being struck causing serious injury or death. Always keep your head away from and out of the jack handle path of movement.

The jack handle may move rapidly when moving the reversing latch and cause serious injury or death. Always place the handle against the steel standard bar with the handle clip spring holding it up before moving the reversing latch. This will prevent the handle from moving up and down rapidly. Securely hold on to the jack handle so your hands do not slip and ensure the handle is not in the horizontal position when moving the reversing latch.

Important! During lifting and lowering, the weight of the load pushes up against the jack's handle. If your hands slip off the handle, or if the handle is horizontal when you move the reversing latch, it may move up very quickly.

Attempting to lift more than one wheel at a time may result in tip over, unexpected movement, and serious injury or death.

⚠ WARNING

The following hazards or unsafe practices may cause serious injury or death

The jack, while standing vertical and unsupported, may tip over and cause serious injury or death. Always support the jack or lay it on its side when not in use.

This jack will not operate safely without proper lubrication. Using the jack without proper lubrication will result in poor performance and damage to the jack. The jack is not self-lubricating, inspect the jack before use and lubricate when necessary.



Important! First Responder Jacks are designed to be operated by properly trained and clothed rescue personnel in emergency or emergency training applications only.

All users must read and understand the instructions and safety warnings in the instruction manual and on this product before using the jack. Each user must use the jack safely and maintain it properly.

If any users are not fluent in English, have someone read the instructions to them. Manuals are also available in other languages upon request at no charge.

If you have any questions about using the jack safely, need a new label or manual contact:

Hi-Lift Jack Company
P.O. Box 228
Bloomfield, IN 47424-0228 USA

Toll Free: 800.233.2051
Direct: 812.384.4441
Fax: 812.384.4592
Web: <http://firstresponder.hi-lift.com>

may result in tip over, unexpected movement, and serious injury or death. Always securely chock, wedge, and block (6 points minimum) to avoid tip over.

Handle force required to raise 4,660 lbs. is 177 lbs. at 34" on the handle. Maximum rated load is 4,660 lbs. (2273 kg) up to 48" (121 cm), tested to 7,000 lbs. (3175 kg). Upper 12" of 60" jack is rated to 2,660 lbs. (1209 kg) only, tested to 4,000 lbs. (1818 kg). If you overload the jack during operation, the shear bolt will break. If the shear bolt breaks, as it will at 7,000 lbs. (3175 kg), the load should be supported, but the jack's handle will drop freely. Use a jack with a larger load capacity to lower the load safely to the ground. Do not replace the shear bolt with a bolt of greater strength as this could cause the jack to fail and drop the load. Always use a shear bolt supplied by Hi-Lift Jack Company. Do not replace the shear bolt while the jack is under load.

⚠ WARNING

The following hazards or unsafe practices may cause serious injury or death

The jack, while standing vertical and unsupported, may tip over and cause serious injury or death. Always support the jack or lay it on its side when not in use.

This jack will not operate safely without proper lubrication. Using the jack without proper lubrication will result in poor performance and damage to the jack. The jack is not self-lubricating, inspect the jack before use and lubricate when necessary.



Important! First Responder Jacks are designed to be operated by properly trained and clothed rescue personnel in emergency or emergency training applications only.

All users must read and understand the instructions and safety warnings in the instruction manual and on this product before using the jack. Each user must use the jack safely and maintain it properly.

If any users are not fluent in English, have someone read the instructions to them. Manuals are also available in other languages upon request at no charge.

If you have any questions about using the jack safely, need a new label or manual contact:

Hi-Lift Jack Company
P.O. Box 228
Bloomfield, IN 47424-0228 USA

Toll Free: 800.233.2051
Direct: 812.384.4441
Fax: 812.384.4592
Web: <http://firstresponder.hi-lift.com>

General Safety

Training

- Read this manual before use. Do not allow anyone who has not read this manual, and/or does not understand the requirements, use the jack.
- Important! First Responder Jacks are designed to be operated by properly trained and clothed rescue personnel in emergency or emergency training applications only.

Spectators

- Do not allow bystanders around the jack or under the load supported only by the jack.

Inspection

- Inspect the jack carefully before each use. Ensure the jack is not damaged, excessively worn, or missing parts.
- Check the climbing pins to make sure that they are not worn or damaged.
- Check the steel standard bar to make sure that it is straight and that nothing is blocking the steel standard bar holes.
- Do not use the jack unless it is in good clean working condition.
- Do not use the jack unless it is properly lubricated.
- Using a jack that is not in good clean working condition or properly lubricated may cause serious injury (see *Lubrication*).

Chock, Wedge and Block - 6 Points Minimum (Stabilize)

A chock is for steadying an object and holding it motionless, or for preventing the movement of a wheel. Chock both sides of wheels that will remain in contact with the ground.

When you block a load, you secure and support a load that is being lifted. The block(s) or stabilizer(s) should have a weight capacity that is greater than the weight of the load which is being lifted. Blocks can be made of wood, plastic or metal. Do not stack more than three blocks in the same direction.

If necessary, a wedge can be used in conjunction with blocks to support loads that are lifted between block heights. Do not use the jack to support the load.

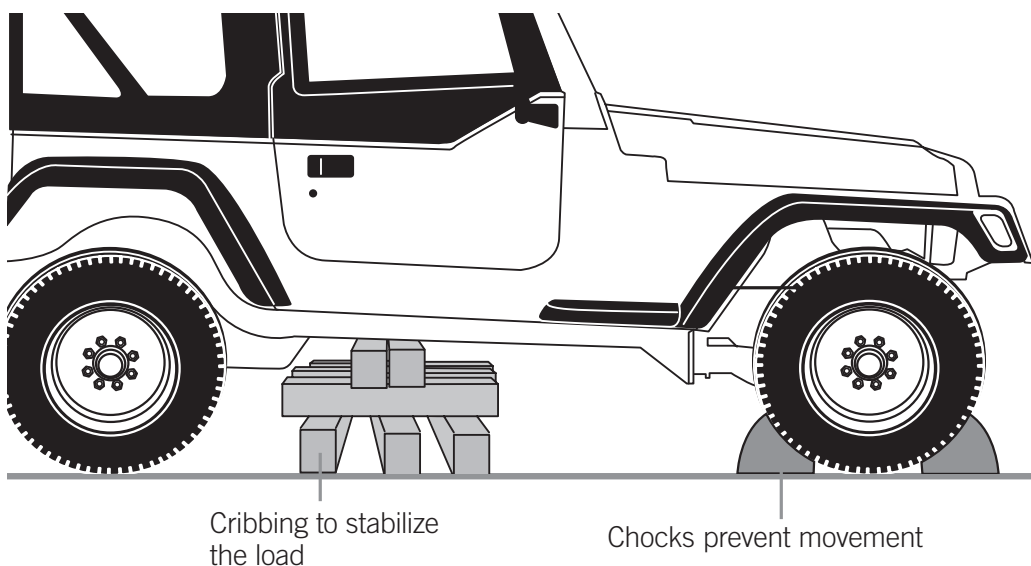

Operation Instructions

Attaching and Using the First Responder Base

⚠ DANGER



Inadequate strength of the cribbing or blocking of the load being lifted may result in the load tipping or slipping off the jack and falling, causing serious injury or death. The cribbing or blocking must have equal or greater strength than the load being lifted.

Rotation of the steel standard bar and first responder base when under load may cause the jack to fail and cause serious injury or death. Do not rotate the bar and base when the jack is under a load. Safety retainer pin must be completely inserted and locked before any load is lifted.

Use of the first responder base for winching when under load may cause the jack to fail and cause serious injury or death. The first responder base is not rated for tension. Do not use the first responder base for winching when under a load.

Attaching the First Responder Base

Prior to lifting a load:

1. Check the rotating hub is securely attached to the standard bar.
2. Place the rotating hub into the first responder base and rotate the rotating hub to the desired position.
3. Align the holes in the hub and base. Insert the safety retaining pin through the holes.
4. Securely lock the safety retainer pin.
5. Check to make sure the safety retainer pin is securely engaged and locked before using.

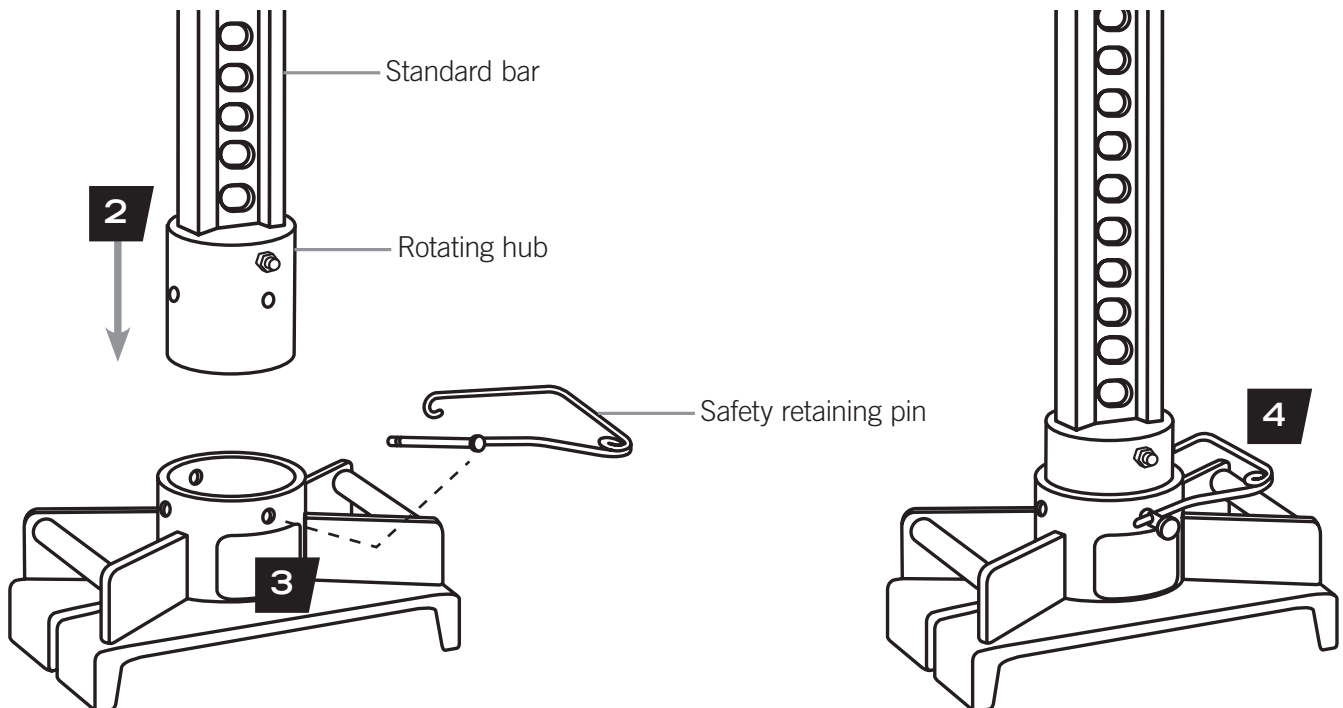

Using the First Responder Base

Follow these guidelines when using the first responder base:

- The chain slot is **not** designed for a chain smaller than 5/16 with a working load that exceeds the rating of the jack.
- When using the jack in an elevated position (other than solid ground) tie backs, straps, or chains must be used to prevent kick-out.
- When a chain is being used to support the jack the angle between the chain anchor and the standard steel bar cannot be more than 45° degrees.

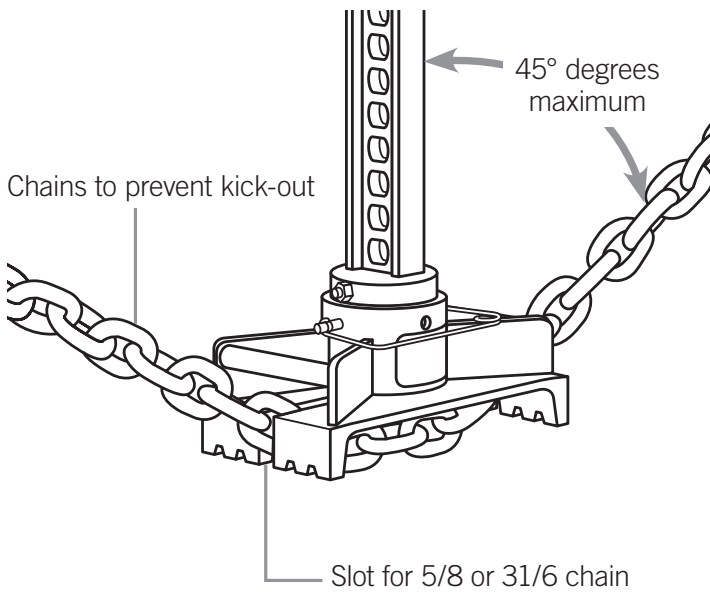

Jack secured with chain

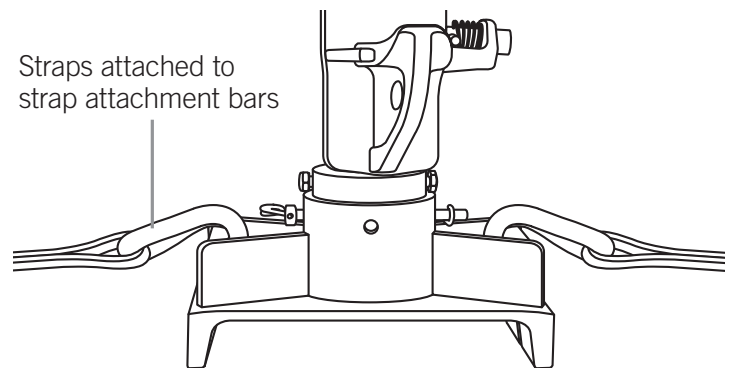

Jack secured with strap

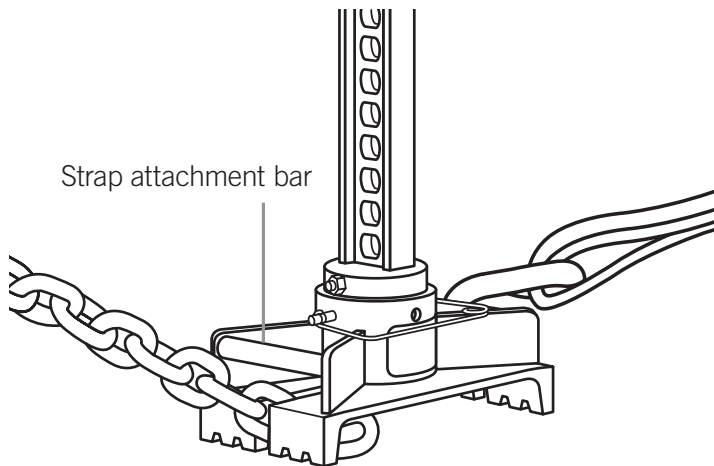

Jack secured with strap and chain

Raising a Stationary Load

⚠ DANGER



DO NOT USE THE JACK TO SUPPORT OR STABILIZE A LOAD. Using the jack to support or stabilize a load may result in unexpected movement and result in serious injury, being crushed and death. Always securely chock, wedge, and block (stabilize) the load to be lifted (6 points minimum). Never place any part of the body under a raised load without properly chocking and supporting the load at a minimum of six points.



Using the jack on curved or tubular vehicle bumpers will result in the vehicle slipping off the jack and falling, causing serious injury or death. Use the Bumper Lift or Lift-Mate to lift most vehicles with curved bumpers or plastic bumpers.

Unexpected movement of the jack handle may result in the user being struck causing serious injury or death. Always keep your head away from and out of the jack handle path of movement.

The jack handle may move rapidly when moving the reversing latch and cause serious injury or death. **Always place the handle against the steel standard bar with the handle clip spring holding it up before moving the reversing latch.** This will prevent the handle from moving up and down rapidly. Securely hold on to the jack handle so your hands do not slip and ensure the handle is not in the horizontal position when moving the reversing latch.

Important! During lifting and lowering, the weight of the load pushes **up** against the jack's handle. If your hands slip off the handle, or if the handle is horizontal when you move the reversing latch, it may move up very quickly.



Attempting to lift more than one wheel at a time may result in tip over, unexpected movement and serious injury or death. Always securely chock, wedge and block the load (six points minimum) to avoid tip over.

Handle force required to raise 4,660 lbs. is 177 lbs. at 34" on the handle. Maximum rated load is 4,660 lbs. (2273 kg) up to 48" (121 cm), tested to 7,000 lbs. (3175 kg). Upper 12" of 60" jack is rated to 2,660 lbs. (1209 kg) only, tested to 4,000 lbs. (1818 kg).

If you overload the jack during operation, the shear bolt will break. If the shear bolt breaks, as it will at 7,000 lbs. (3175 kg), the load should be supported, but the jack's handle will drop freely. Use a jack with a larger load capacity to lower the load safely to the ground. Do not replace the shear bolt with a bolt of greater strength as this could cause the jack to fail and drop the load. Always use a shear bolt supplied by Hi-Lift Jack Company. Do not replace the shear bolt while the jack is under load.

Operation · Raising a Stationary Load

1. Securely chock and stabilize the load to prevent it from rolling or shifting as you lift it (see General Safety: Chock, Wedge and Block).
2. Place the jack's base securely on a firm, level, and dry surface. If the jack cannot be placed on a firm, level and dry surface then restrain the jack with a strap or chain.
3. Lift the reversing latch until it locks in the **up** position.
4. Pull the handle away from the steel standard bar, releasing the handle clip spring.
5. Grasp the handle or the handle socket and raise the lifting mechanism until the large runner is completely and securely under the load.

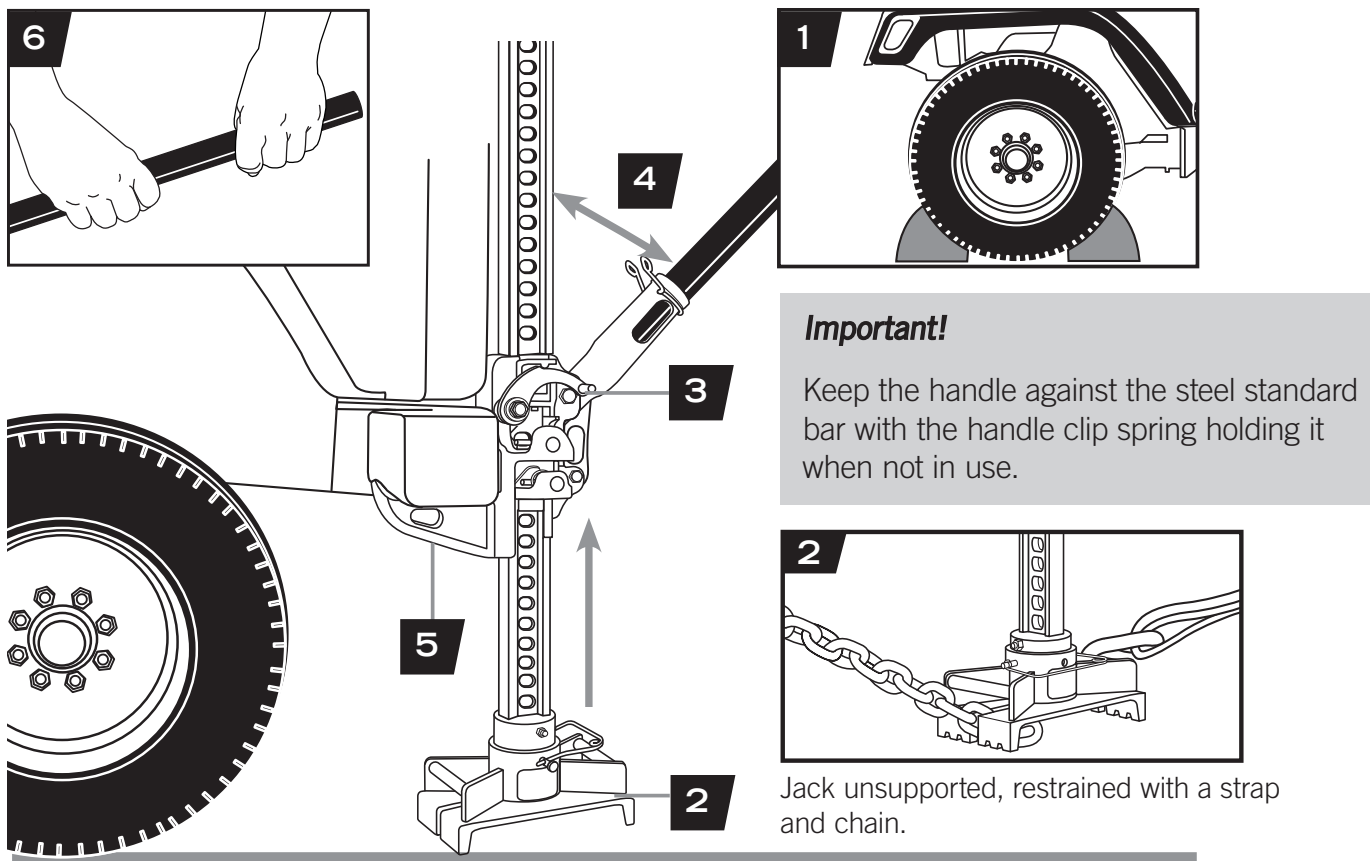

6. Grasp the handle firmly with both hands. Carefully pump the handle up and down to raise the load. Do not use an extension or “cheater” bar on the handle.

The load will be raised on each **down** stroke of the handle. Watch the load and the jack carefully. Stop lifting if either one starts to shift. Do not continue until it is safe to do so. When safe, stabilize and block the load.

7. When the load is raised to the desired height, place the handle in the upright position clipped to the steel standard bar.
8. Block, wedge and chock (minimum six points) the load securely.
9. Lower the load onto the blocks (see *Lowering a Stationary Load*).
10. Remove the jack from the stabilized load.

Lowering a Stationary Load

⚠ DANGER



Unexpected movement of the jack handle may result in the user being struck causing serious injury or death. Always keep your head away from and out of the jack handle path of movement.

The jack handle may move rapidly when moving the reversing latch and cause serious injury or death. **Always place the handle against the steel standard bar with the handle clip spring holding it up before moving the reversing latch.** This will prevent the handle from moving up and down rapidly. Securely hold on to the jack handle so your hands do not slip and ensure the handle is not in the horizontal position when moving the reversing latch.

Important! During lifting and lowering, the weight of the load pushes **up** against the jack's handle. If your hands slip off the handle, or if the handle is horizontal when you move the reversing latch, it may move up very quickly.

The jack must have a load of 150 lbs. or more to lower step-by-step. Otherwise, the lifting mechanism will slide down to the base plate, **dropping** your load. Ensure all bystanders are clear of the load being lowered.

1. Position the jack under the raised load and raise the stationary load (see *Raising a Stationary Load*).
2. Be sure the handle is in the upright position clipped to the steel standard bar **before** lowering the load.
3. Move the reversing latch to the **down** position.
4. Grasp the handle firmly with both hands. Carefully pump the handle up and down to lower the load.
5. The load will be lowered on each **up** stroke of the handle (refer to *Binding* if the jack binds).
6. As the jack is lowered (chase load with wedges), incrementally reduce the height of the cribbing under the load.

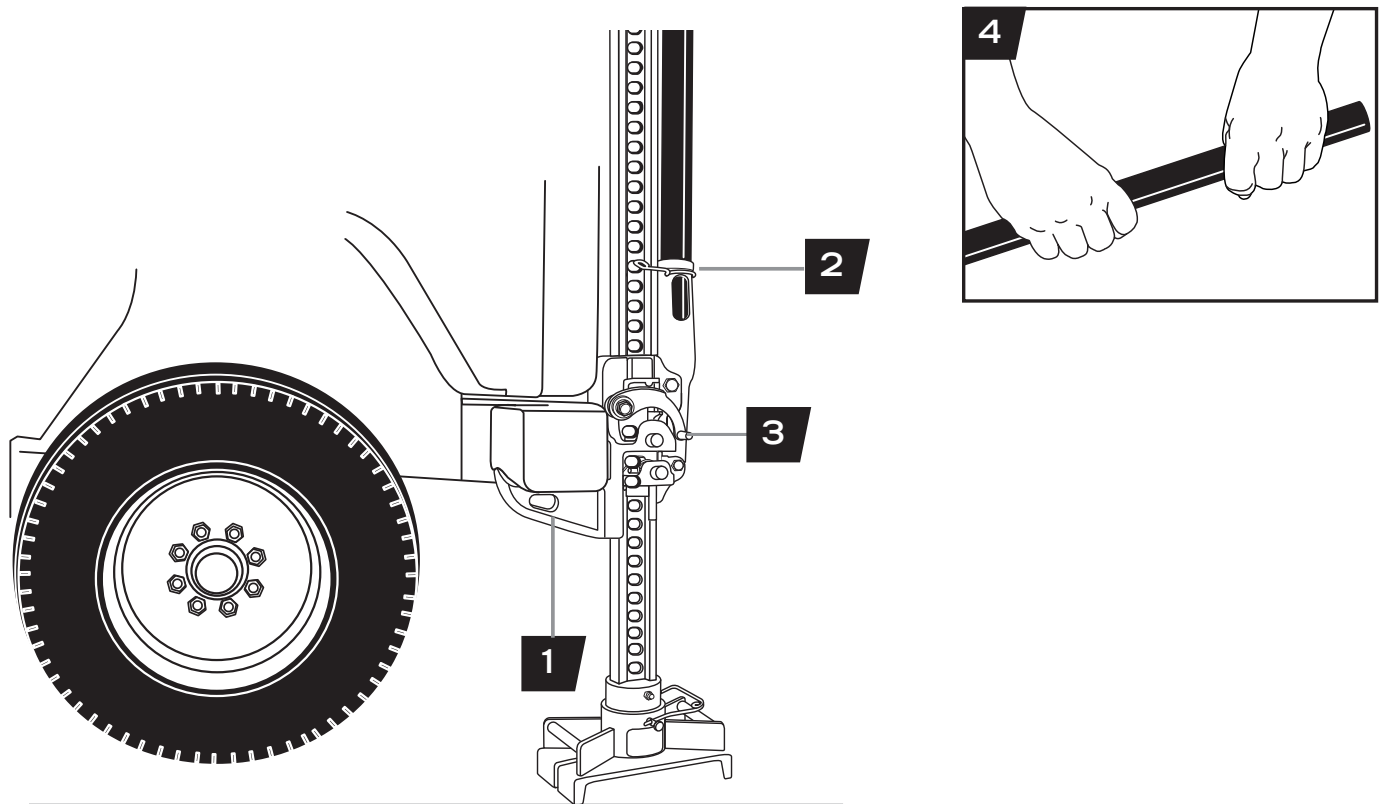

Clamping or Winching

⚠ DANGER



When using the jack as a winch:

Always use chains or tow straps that have a greater working load than the jack. If a chain or tow strap breaks while winching, the load could shift or the chain or tow strap could snap back.

When used as a winch, the top clamp-clevis will support up to 5,000 lbs. (2273 kg). Going over this limit will result in the top clamp-clevis bending or breaking, causing the load to move or the chain or tow strap to snap back. This will result in serious injury or death.

When using the jack for clamping, the maximum clamping force of the top clamp-clevis is 5,000 lbs. (2,273 kg). If you exceed this limit, the top clamp-clevis could bend or break, resulting in serious injury or death.

Clamping

1. Loosen the top clamp-clevis bolt & nut
2. Adjust the top clamp-clevis for the desired winching, clamping, or spreading application. **Re-tighten the bolt.**

Note: You can connect the top clamp-clevis anywhere along the steel standard bar to use the jack as a clamp.

3. Operate the jack as you would for raising a load (see *Raising a Stationary Load*).

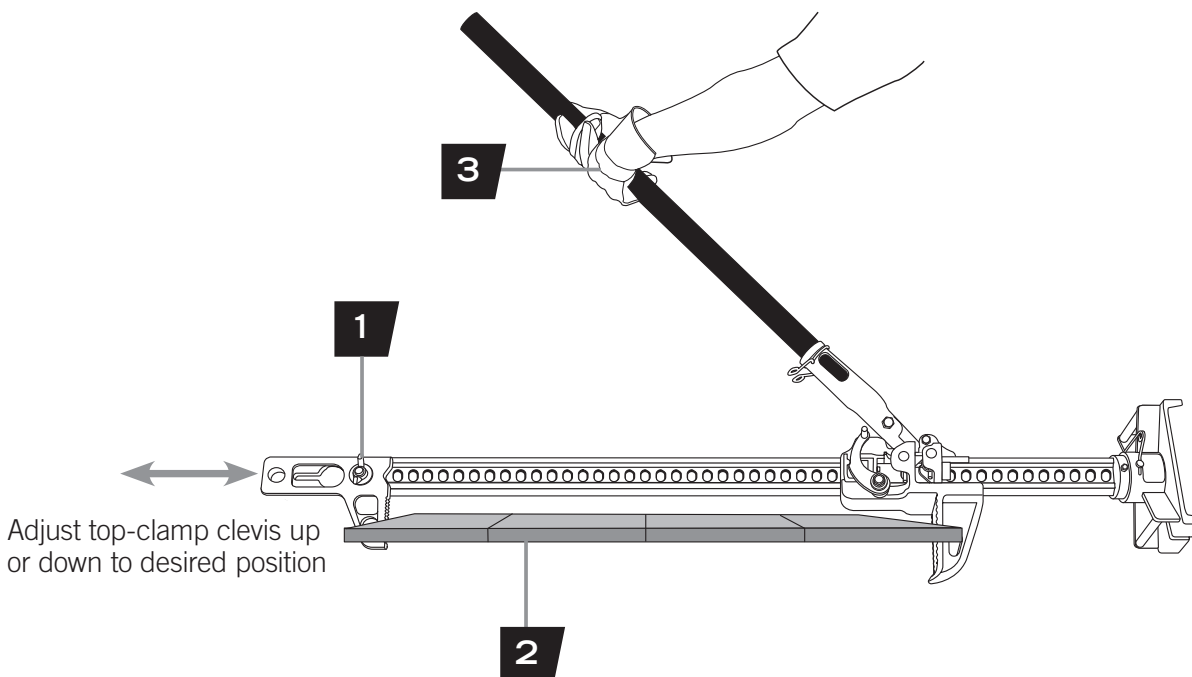

Winching

1. Make sure the top clamp-clevis is secure to the steel standard bar.
2. Install one end of a chain or tow strap securely to the object to be winched. Securely attach the other end of the chain or tow strap to the top clamp-clevis of the jack.

Note: Use a shackle if the chain or tow strap will not fit through the top clamp-clevis of the jack.

3. Take another chain or tow strap and secure one end to a fixed, stable object. Attach the other end of the chain or tow strap to the large runner on the jack (do not attach chain or shackle to bottom hole of the large runner on the jack).
4. Operate the jack as you would for raising a load (See Raising a Stationary Load).

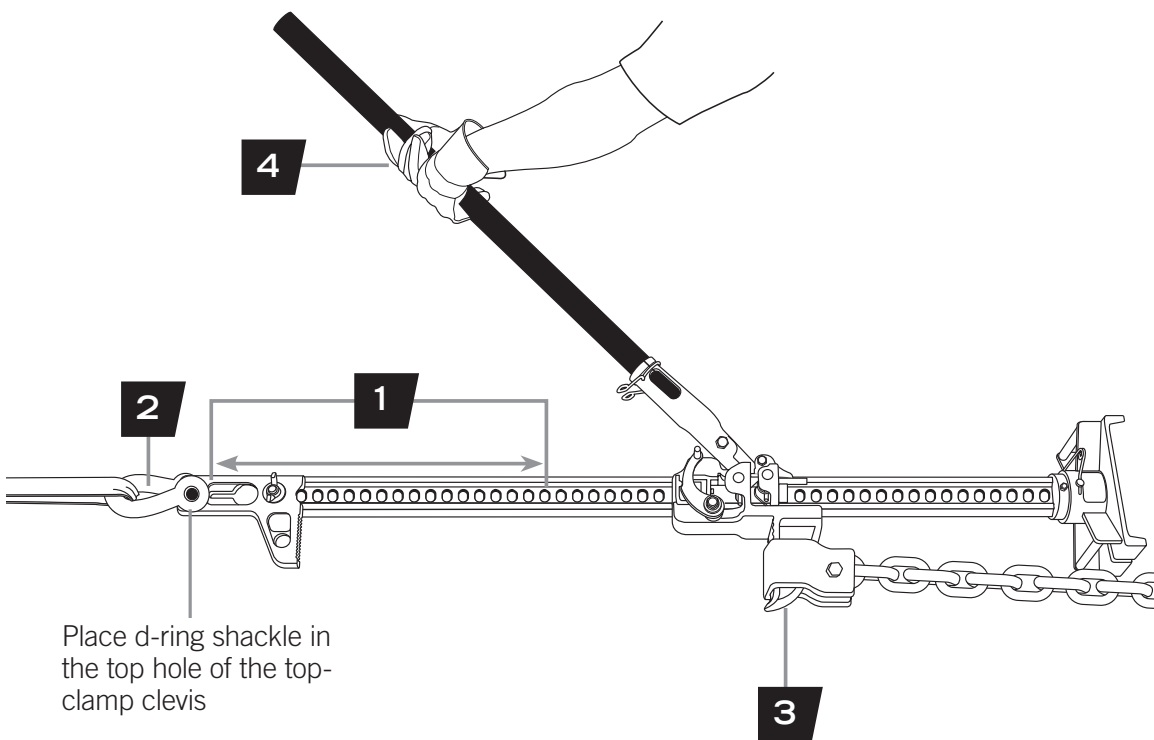

Tip: Use the Hi-Lift Off-Road Kit for items you need for winching which includes custom winch attachments and a d-ring shackle.

Maintenance Instructions

If you use and maintain your First Responder Jack properly, it will give you many years of service. Follow the maintenance instructions carefully to keep your jack in good working condition. NEVER PERFORM MAINTENANCE ON THE JACK WHILE IT IS UNDER LOAD.

Cleaning

If the moving parts of the jack or the standard bar are clogged, use air pressure, water pressure, or a stiff brush to clean. Use a non-flammable cleaning solvent or another good de-greaser to clean the jack. Remove any existing rust, preferably with a penetrating lubricant.

Binding

If the climbing pins start to bind in the holes of the standard bar the jack will not operate properly and safely. Rusty climbing pins, dirt, or worn bar can be causes of binding.

Clean and lubricate the lifting mechanism as indicated in the Lubrication section. Test the jack by lifting it up without a load. If the binding continues, send it to our Factory Service for repair. If the jack binds while under a load, use a jack with equal or larger load capacity to lower the load safely to the ground. After unbinding the jack clean, lubricate and test as described at the start of this paragraph.

Storing the Jack

1. Place the handle in the upright clipped position against the steel standard bar.
2. Raise the reversing latch until it locks in the **up** position.
3. Store in the upright clipped position in a dry location, preferably indoors.

Tip: If the jack is stored outdoors, consider using a Hi-Lift protective cover accessory.

Inspection

You should inspect the jack for damage, wear, broken or missing parts (e.g.: climbing pins) and functionality before each use (see *General Safety: Inspection*). Follow lubrication and storage instructions for optimum jack performance.

Lubrication

⚠ WARNING

Using the jack without proper lubrication will result in poor performance and damage to the jack. The jack is not self-lubricating, inspect the jack before use and lubricate when necessary. After cleaning, lubricate the jack using light penetrating oil, or a silicon or Teflon spray at the following points:

Steel Standard Bar: Keep the front and back edges lightly lubricated and free from dirt and rust.

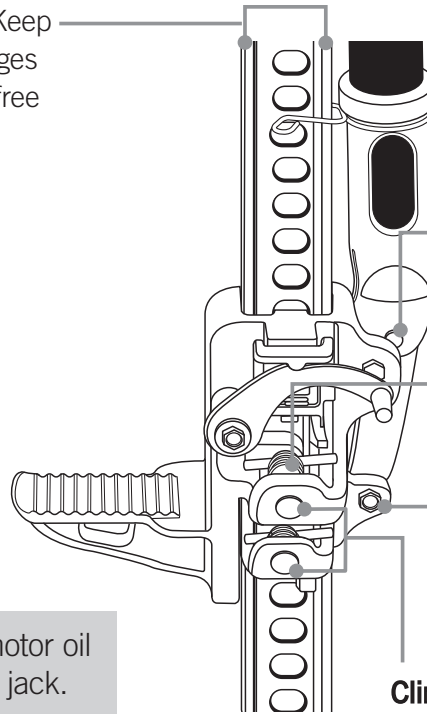

Pitman Pin: Damage to the handle socket will occur if not lubricated

Springs: Keep clean and lubricated and free from dirt and rust.

Shear Bolt: Wear to the bolt will occur if not lubricated

Climbing Pins: Keep clean and lubricated and free from dirt and rust

Important! Do not use motor oil or grease to lubricate the jack.

Repair

If you need to repair your jack, use only genuine Hi-Lift parts. Using parts not supplied by Hi-Lift® Jack Company will make the jack unsafe for use and void the warranty. Hi-Lift® will repair a damaged jack. Pack the jack in a carton and send prepaid to the address below:

Hi-Lift® Jack Company
 Factory Service Department
 46 West Spring Street
 Bloomfield, Indiana 47424

The repaired jack will be returned to you via USPS, UPS or Fed Ex.

Parts

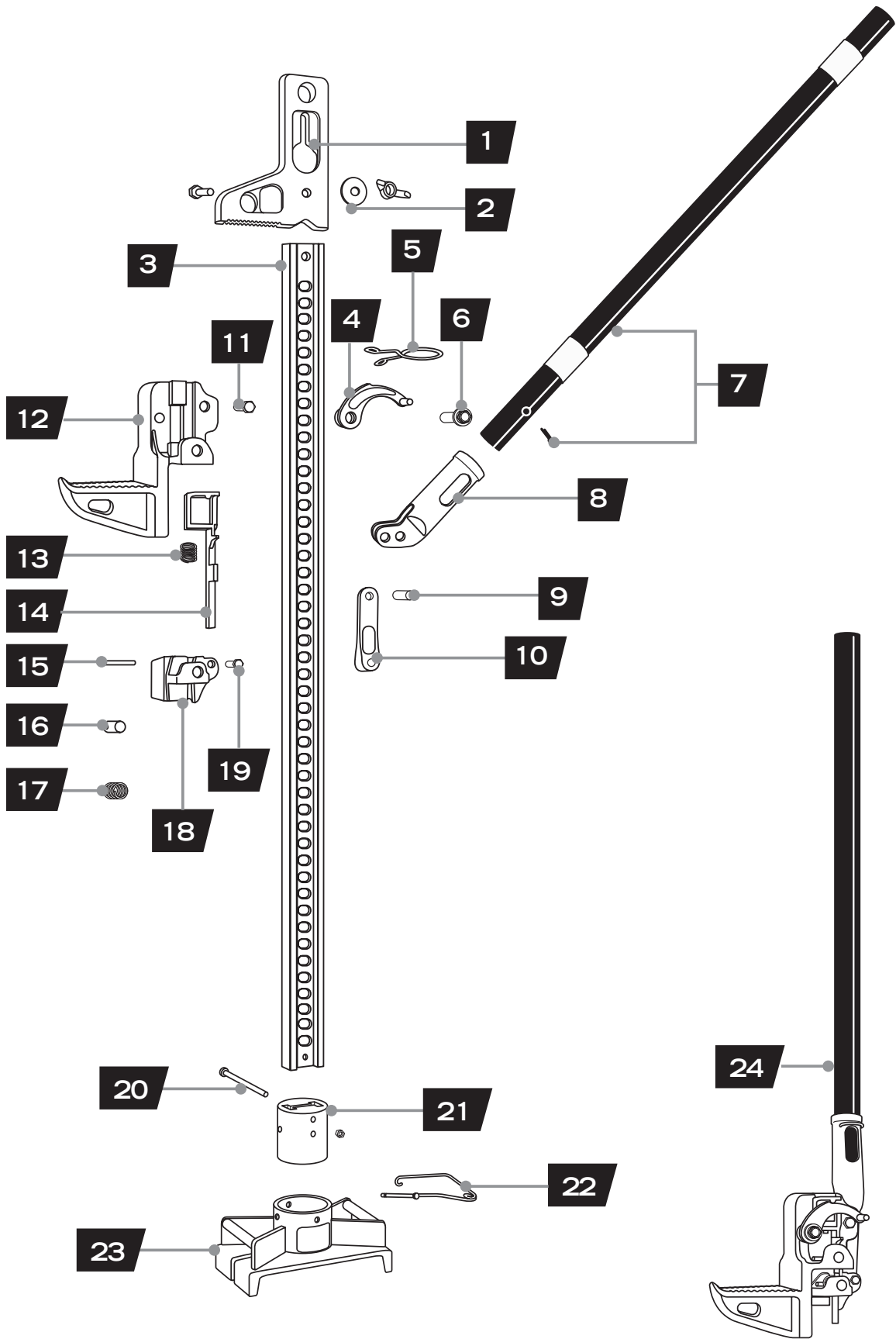

The following are the parts for all Hi-Lift jacks. You can order parts from your dealer or directly from our factory by calling (800) 233-2051 (or 812-384-4441 from outside the USA). For other options visit www.hi-lift.com.

1. Top clamp-clevis (winch, clamp, spreader attachment)
2. Top clamp-clevis bolt & nut
3. Steel standard bar
4. Reversing latch
5. Handle clip spring
6. Cap screw with washer
7. Steel handle with cotter pin
8. Handle socket
9. Pitman pin
10. Pitman
11. Hex bolt & nut
12. Large runner
13. Reversing switch spring
14. Reversing switch cam bar
15. Cross pin
16. Climbing pin
17. Climbing pin spring
18. Small runner
19. Shear bolt & nut
20. Rotating hub retaining screw & nut
21. Rotating hub
22. Safety retaining pin
23. First Responder base
24. Complete running gear

Specifications

		36" First Responder Jack	48" First Responder Jack	60" First Responder Jack
Weight	lbs	27.00	30.20	33.30
	kg	12.25	13.70	15.10
Width	in	5	5	5
	cm	12.70	12.70	12.70
Height	in	41	50.75	61.75
	cm	104.14	128.91	156.85
Depth	in	9.63	9.63	9.63
	cm	24.46	24.46	24.46
Rated Load	lbs	4,660	4,660	4,660
	kg	2113.74	2113.74	2113.74
Rated Load Upper 12"	lbs	N/A	N/A	2,660
	kg	N/A	N/A	1206.55
Tested Load	lbs	7,000	7,000	7,000
	kg	3175.14	3175.14	3175.14
Tested Load Upper 12"	lbs	N/A	N/A	4,000
	kg	N/A	N/A	1814.37
Clamping	lbs	5,000	5,000	5,000
	kg	2267.96	2267.96	2267.96
Winching	lbs	5,000	5,000	5,000
	kg	2267.96	2267.96	2267.96
Max. Lift height at Nose	in	27	38.63	49.75
	cm	68.58	98.12	126.37
Min. Lift height at Nose	in	6.75	6.75	6.75
	cm	17.14	17.14	17.14

Limited Warranty

Limited Warranty

Hi-Lift® Jack Company warrants the First Responder jack for 12 months from the date of purchase, only to the original owner, against defective materials and workmanship. Return the jack or parts thereof, transportation prepaid and with proof of purchase, to the Factory Service Department, Hi-Lift® Jack Company, 46 West Spring Street, Bloomfield, IN 47424. This warranty is void if the jack is modified, used beyond rated capacity, if an extender is used on the handle, or if the jack is abused, misused, not maintained properly, or if non-Hi-Lift® replacement parts are used. This warranty replaces all previous warranties and is the only warranty made by the Hi-Lift® Jack Company on this product. No other warranties, either verbal or written, are authorized. This warranty gives you specific legal rights. You may also have other legal rights that vary from state to state.

Warranty Registration

Name (print): _____

E-mail: _____

Address: _____

City: _____ State: _____ Zip: _____

Phone number: _____

Is this your first First Responder Jack? YES NO

Date you received First Responder Jack: Month: _____ Day: _____

Year: _____

Model Number: _____ Purchase Price: _____

Store First Responder Jack Purchased from: Store Name: _____

City: _____ State: _____

How did you learn about the First Responder Jack?

Brochure Internet: _____

Retail Store Magazine: _____

Catalog Friend

Trade Show Other: _____

Cut along dotted line. Mail registration.

Cut along dotted line. Mail registration.

See our website at <http://firstresponder.hi-lift.com>
for information on all Hi-Lift products



Hi-Lift Jack Company

P.O. Box 228
Bloomfield, IN 47424-0228 USA

Toll Free: 800.233.2051

Direct: 812.384.4441

Fax: 812.384.4592

Web: <http://firstresponder.hi-lift.com>